



Please contact our service department for help with any concerns or questions about your R&P Valve.

SCHLAGEL

491 North Emerson Street • Cambridge MN 55008-1316 U.S.A.
Toll Free (800) 328-8002 FAX (763) 689-5310
Local / International (763) 689-5991 EMAIL sales@schlagel.com
www.schlagel.com

R&P VALVES

Installation and Operation Manual

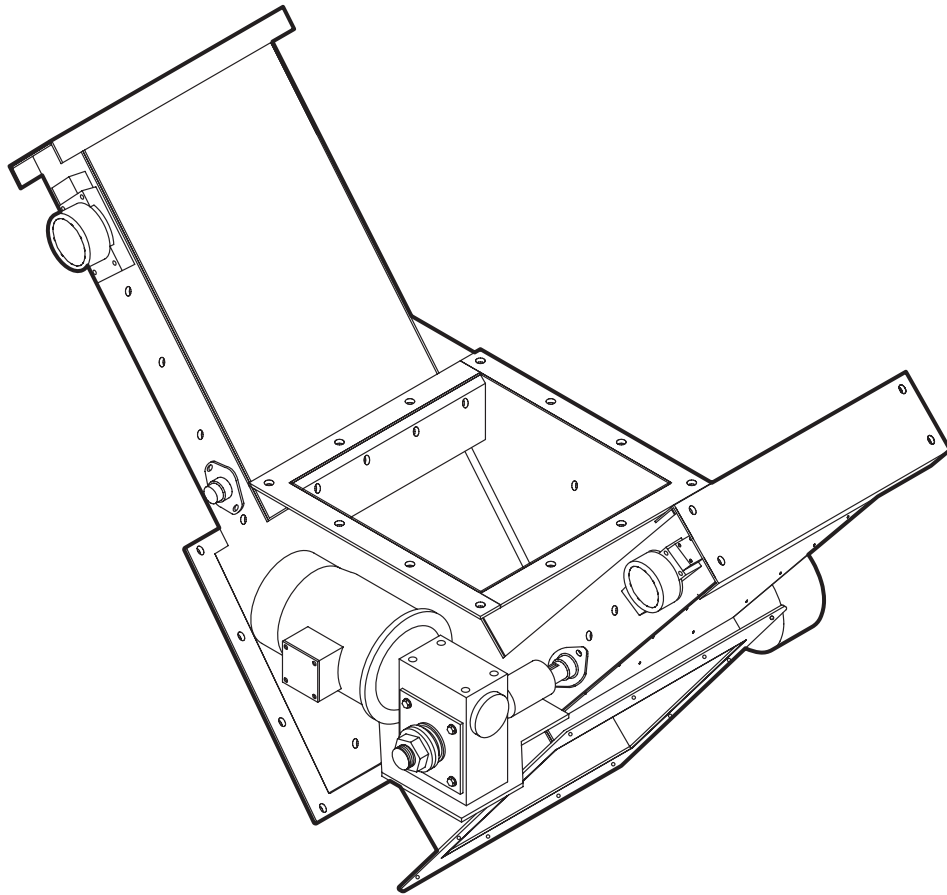

Manual-Air-Electric Operators

SCHLAGEL

Manufacturers of Innovative Materials Handling Equipment since 1957.

491 North Emerson Street * Cambridge MN 55008-1316 U.S.A.
Toll Free (800) 328-8002 FAX (763) 689-5310
Local / International (763) 689-5991 EMAIL sales@schlagel.com
www.schlagel.com

TABLE OF CONTENTS

SECTION 1 - GENERAL

Pages	1	Introduction
	1	Use of Manual
	2	Information Service
	2	Uncrating and Inspection
	2	Safety Code
	3	General Notes
	4	Routine Maintenance

SECTION 2 - ASSEMBLY AND INSTALLATION

Pages	5	Manually Operated R&P Valve
	6	Air Operated R&P Valve
	7	Electric Operated R&P Valve
	8	Hampton Worm Gear Reducer
	9	Typical Electrical Air Solenoid valve connections
	10	Typical Wiring Diagrams

INTRODUCTION

The Schlager R&P Valves have been designed to give you many years of faithful service. The R&P Valves are available using a variety of operators. Some of the more common operators are shown in this manual. The instructions in this manual should be adhered to as closely as possible to ensure proper installation and operation. These instructions are suggestions to help the installer determine the best way to mount the unit.

USE OF MANUAL

This manual provides installation, operation, service recommendations and replacement parts identification for the Schlager R&P Valve.

Each section of the manual is fully illustrated for fast, accurate reference. It is highly recommended that this manual be read thoroughly by those who are responsible for the installation, operation and maintenance of this valve. Refer to the Table of Contents, on this page for the location of specific information.

As new information and equipment become available, service and parts bulletins will be issued by Schlager Inc. so that they will be readily available for reference, all bulletins should be inserted with this manual. For other items or special equipment not covered in this manual, please consult our service department for recommendations or instructions regarding this equipment.

INFORMATION SERVICE

Enclosed with your R&P Valve shipment is our packing list that details all items on your order. This packing list should be saved for future reference. The invoice number shown on this document is the same as the serial number shown on your valve I.D. tag. If you ever need to call the factory for parts or service it is very helpful to have this serial number available. Please record the information below and save this booklet for future reference.

Date of Purchase: _____

Serial Number: _____

Model: _____

Purchased from: _____

Email or Call: Schlager, Inc.
 491 North Emerson Street
 Cambridge, MN 55008
 (763) 689-5991 or 1-800-328-8002
 sales@schlager.com

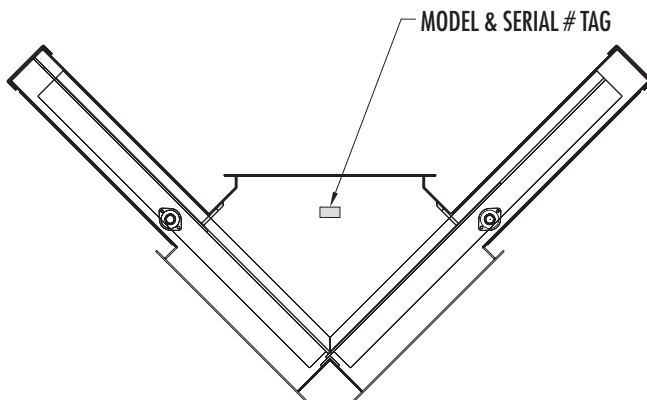

UNCRATING AND INSPECTION

Your valve has been carefully checked and operated before shipment from our factory. In the event that any parts are missing or damaged, please notify us immediately and also have the delivering carrier note this on the Bill of Lading.

IMPORTANT

All claims for shipping damages must be noted by the consignee at the time of delivery and filed with the transportation company.

SAFETY CODE

⚠ WARNING ⚠

The icon shown below was proposed as a safety alert symbol by the Farm and Industrial Equipment Institute (FIEI) and approved by the American Society of Automotive Engineers (ASAE) and others for the purpose of calling attention to safety precautions which if not heeded might lead to bodily injury.

Please read instructions carefully and follow the instructions exactly wherever this symbol appears in the manual.



LOOK FOR THIS SAFETY LABEL

⚠ WARNING ⚠



EXPOSED BELT CHAIN & MOVING PARTS CAN CAUSE SEVERE INJURY

LOCK OUT POWER BEFORE REMOVING GUARD

⚠ WARNING ⚠



MOVING PARTS CAN CAUSE SEVERE INJURY

LOCK OUT ENERGY SOURCE BEFORE INSPECTION OR SERVICE

GENERAL NOTES

- All R&P Valves should have the flange joints caulked or gasketed during installation.
- The R&P Valve is designed to offer the ultimate dependability in diverting bulk materials. It is NOT a "spouting support system". Do not attach long spouting runs or misaligned flange joints that would cause deformation of the valve body and subsequent binding or leaking.
- R&P Valves are designed to be able to be operated while material is running. They are not meant to shear through the product in a plugged spout condition.
- Do not use our R&P Valve with VLF UHMW slide guides in applications where the material is over 200° F.
Consult the factory for steel and/or roller bearing guides.
- R&P Valves can be ordered with synchronized and non-synchronized slides. The two options are shown in the drawings to the right. The R&P Valve is available with a variety of operators.

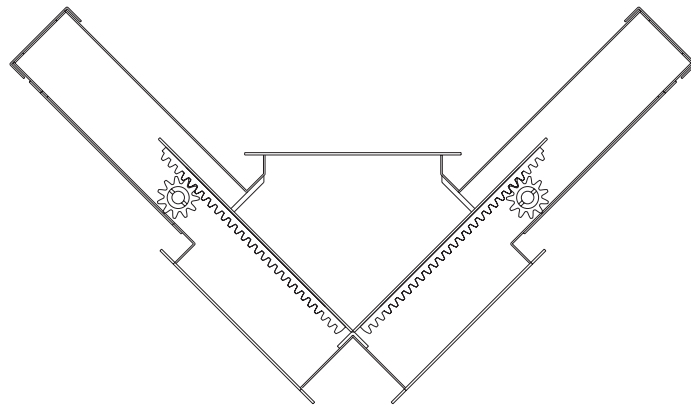

NON-SYNCHRONIZED

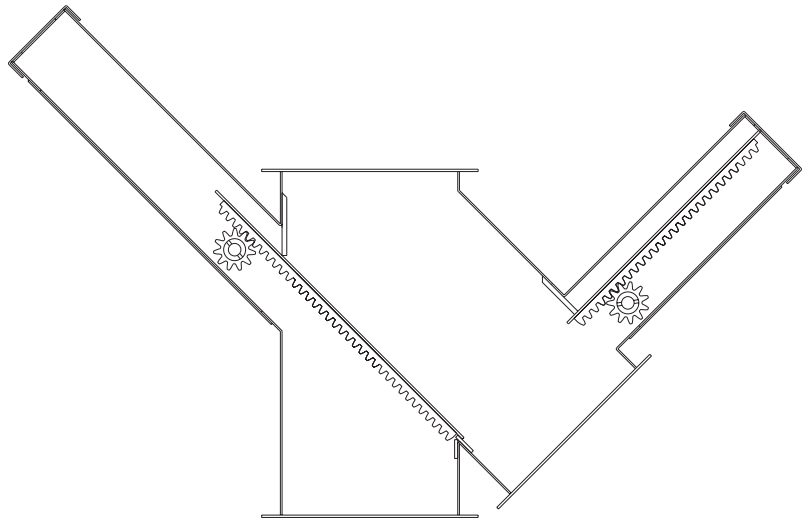

SYNCHRONIZED

ROUTINE MAINTENANCE OF R&P VALVE

- The most common type R&P Valve using our VLF style slide guides has very few moving parts and thus requires little routine maintenance. Since most units include some type of lining for demanding applications, regular inspections should be made to make sure that grain has not worn through the housing or slides.
- Synchronized style valves use a chain to connect the two shafts. This chain drive has a built-in tensioning device. See Figure 1 below. Chain tension should be checked regularly, as allowing the chain to get loose could cause the chain to skip teeth on the sprocket resulting in the slides no longer being properly timed.

Fig. 1

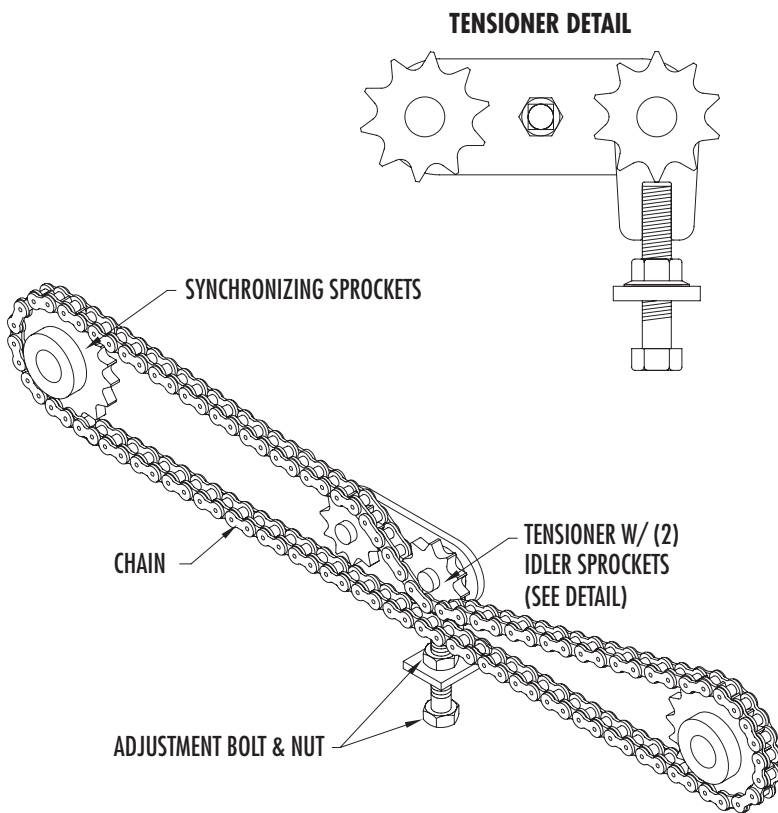

CAUTION



The guard is removed for instructional clarity only.
Always have the guard installed while operating.

MANUALLY OPERATED R&P VALVE NOTES

- When controlling a cable operated valve from a remote location, be certain that any cable runs have as few changes in direction as possible. Each direction change around a pulley will result in poorer operator "feel" of the of valve position. Be especially careful that the cable does not bind against a pulley mounting bracket or some other object. Use a swivel type pulley when necessary.
- Chain wheel operated valves are supplied with a guide to help prevent the chain from coming off the chain wheel. When using a chain wheel, you may wish to use a short length of chain with cable connected to both ends of the chain. This would allow the cable to change directions by going around a pulley.
- With synchronized valves, plainly mark the operating controls so that any personnel can tell from a glance if the valve is in the **LEFT** or **RIGHT** position.

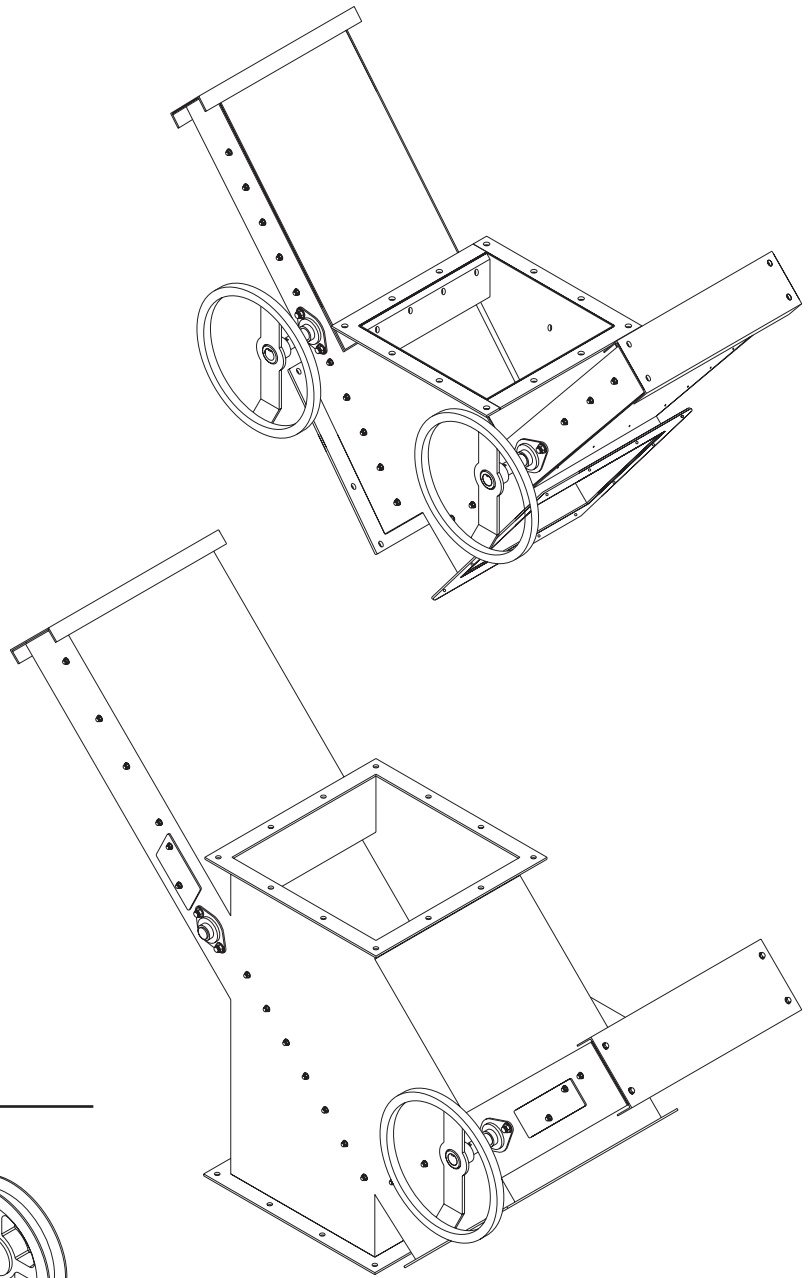

OPTIONAL MANUAL GATE OPERATORS

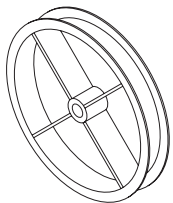

CABLE WHEEL

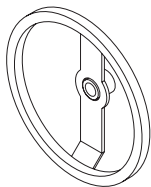

HAND WHEEL

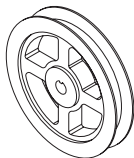

CHAIN WHEEL

AIR OPERATED R&P VALVE NOTES

- Use a clean dry air supply of 100 psi. It is recommended that some type of air dryer be used to remove moisture rather than a simple bowl type filter.
- If a lubricator is installed in the line then use an air system oil that will not harm the seals used in air cylinders or solenoid valves. There are oils available with anti-freeze ingredients for cold weather areas. **Do not use excessive amounts of oil.**
- In cold weather areas, we recommend that electric air solenoid valves be located in a warm control room rather than out by the air cylinder. The freezing that results from moisture in the air line normally happens in the solenoid valve, not the cylinder. Having the solenoid valve in a control room may also eliminate the need for having an explosion proof electrical rating in addition to providing better service access.
- Use adjustable speed controls on large valves that will cycle frequently. This will extend the life of all mechanical components in the valve.
- Use mufflers/filters on the exhausts of any manual or electric solenoid valves to prevent contaminants from getting inside.
- See page 9 for air solenoid hookups and option and page 10 for limit switch wiring schematics.

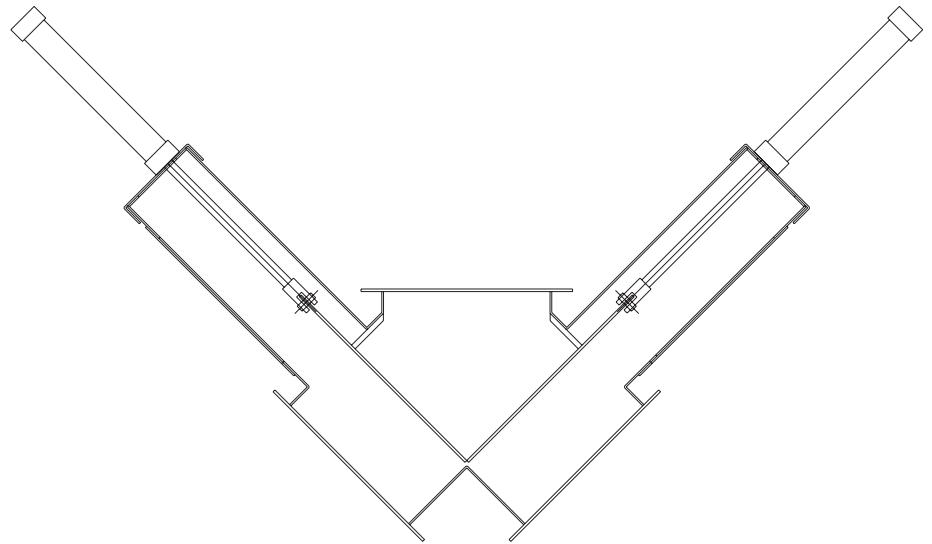

NON-SYNCHRONIZED

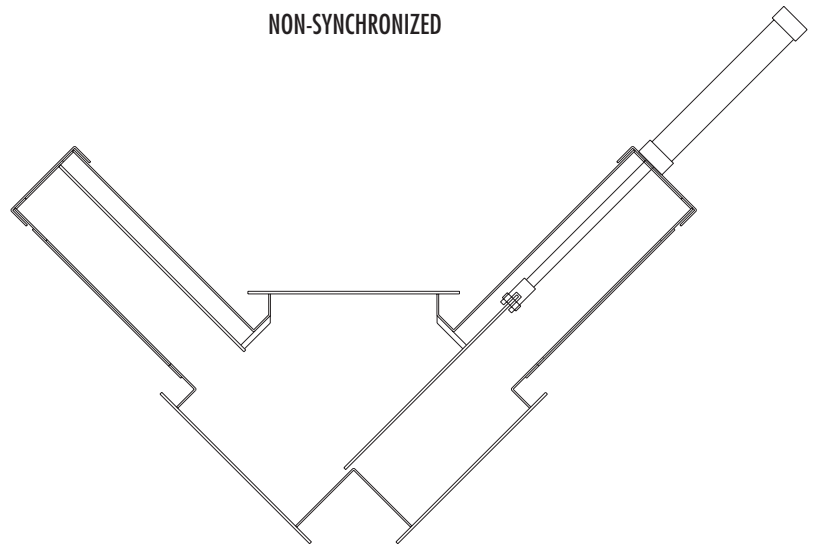

SYNCHRONIZED

ELECTRIC OPERATED R&P VALVE NOTES

- The standard right-angle gear reducer has been filled with Mobil #1 75W-90 synthetic oil. Do not use anything other than a synthetic oil in cold weather areas. This reducer has an internal slip clutch set at the factory to 120lb-ft. Adjustments to this clutch are rarely required, Figure 2 on page 8, explains the procedure should this be necessary.
- Position indication is accomplished with limit switches. We use the Micro-Switch brand switch #LSXYAB4L. This is a DPDT switch offering a high level of versatility in your control system. The most common synchronized style valve uses two switches, one located at the closed position of each slide. Some customers prefer the redundancy of having four switches in which case the extra switches can be used for position confirmation or alternately can be wired in series with the normal two. The non-synchronized style electric valve always uses four switches so the wiring is identical to that of two standard independent slide gates.
- If your Electric Operated R&P Valve is being used as a splitter or some other application requiring position indication at a location other than fully-open/fully-closed we offer several types of position indicators with output to a physical meter or output in 4-20ma for interface with a PLC control.

Contact the factory for details.

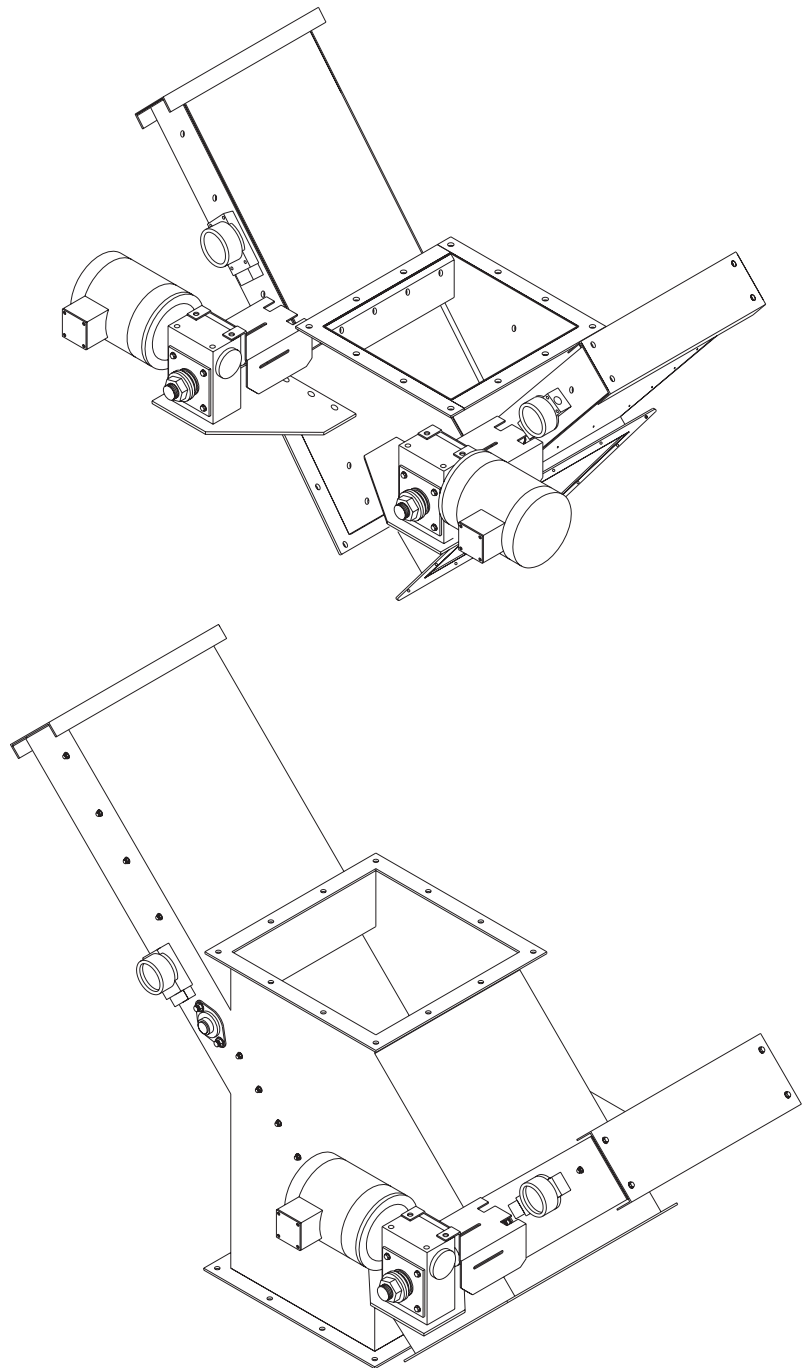
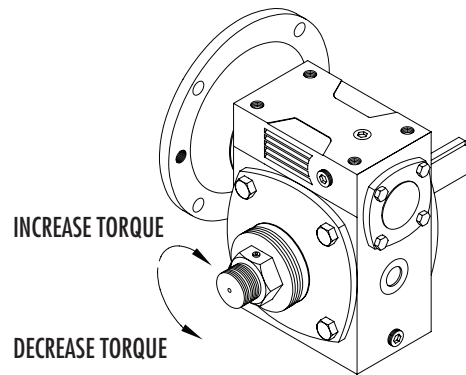

Fig. 2

Hampton Worm Gear Reducer 100:1 Ratio, 56C Frame

This reducer is equipped with a built-in slip clutch. The slip clutch is set at the factory to 120 ft/lbs. In the event the slip clutch needs to be field adjusted, loosen the set screw (using a 5mm allen wrench) and turn the nut as shown using a torque wrench to the desired setting.

The reducer is filled with Mobil #1 75W-90 synthetic lubricant. This provides good service in most normal temperature ranges. As with any gear reducer, the oil should be changed in your normal routine maintenance schedule.



TYPICAL ELECTRICAL AIR SOLENOID VALVE CONNECTIONS

Figure 1

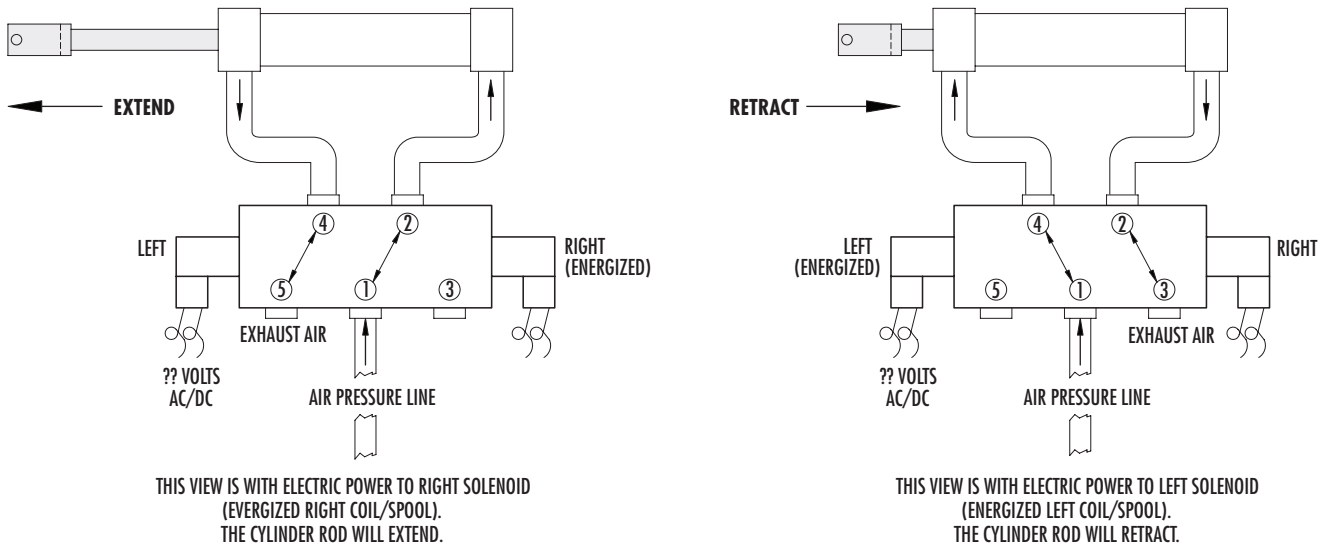

The double solenoid valve shown here is recommended for use on R&P Valves. This style will maintain the slide's position upon loss of electric power and keep the slides from changing positions.

Figure 2

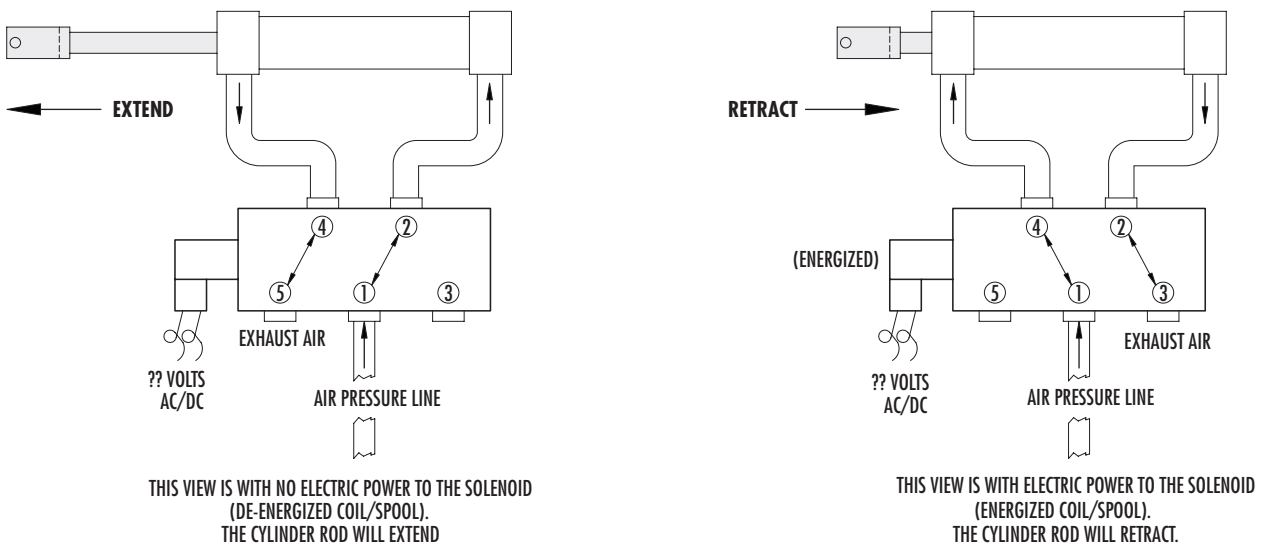

The single solenoid is the style optional for R&P Valves. This style will close the gate upon loss of electric power and thus prevent a bin from emptying.

The above diagram shows typical hookups for air solenoid control valves on R&P Valves.

Figure 1. shows a double solenoid (meaning there are two electrical coils). This type of solenoid valve will keep the rod (and thus the slide) in its last chosen position if there was a loss of power. This is the style supplied by us as a standard on R&P Valves.

Figure 2. shows a single solenoid (meaning a single electrical coil). This type of solenoid valve, when plumbed as shown, will cause the rod to extend as long as there is no power applied. This means that the slide could change position if there was a loss of power. This style is optional.

TYPICAL WIRING DIAGRAM FOR GEARMOTOR DRIVE ON A R&P SLIDE GATE

TYPICAL WIRING DIAGRAM

REMOVE INTERNAL JUMPERS 3 TO 6, 5 TO 7.

✕ BREAK FOR MOMENTARY OPERATION

THE LIMIT SWITCHES ARE THE ONLY DEVICES PROVIDED.

ANY STARTER, PUSH BUTTON CONTROL OR INDICATOR LIGHTS ARE TO BE SUPPLIED BY CUSTOMER.

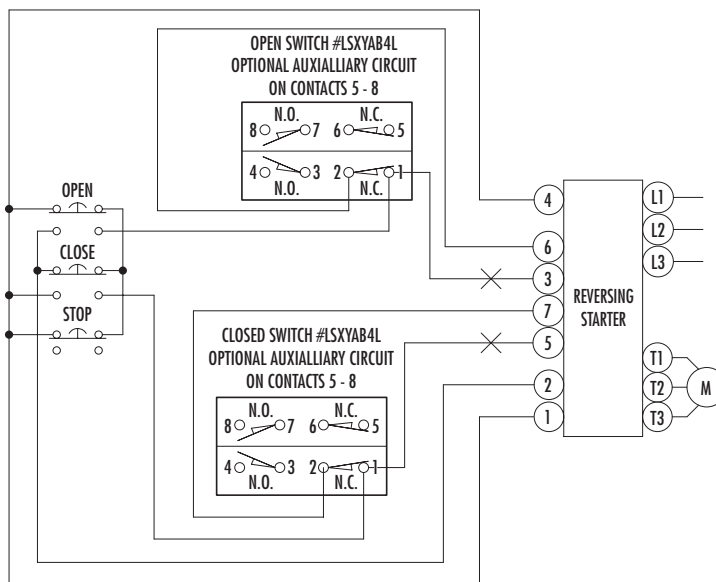

TYPICAL WIRING DIAGRAM FOR POSITION INDICATING SWITCHES ON A R&P SLIDE GATE

TYPICAL WIRING DIAGRAM

(LSXYAB4L DPDT) LIMIT SWITCHES ARE SHOWN AS BEING USED TO LIGHT AN INDICATING LAMP.

CERTAIN EQUIPMENT MIGHT BE USED WITH ONLY ONE LIMIT SWITCH.

THIS DIAGRAM IS NOT TO BE USED FOR CONTROLLING A MOTOR CIRCUIT.

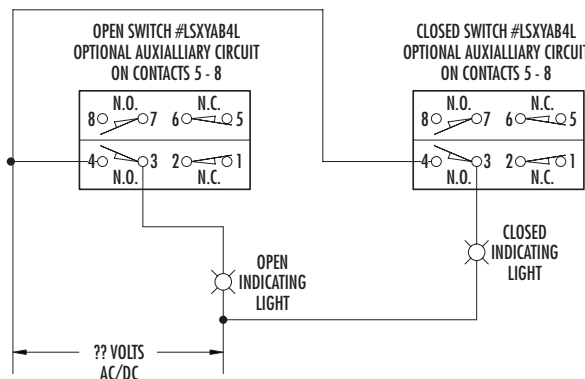

TYPICAL WIRING DIAGRAM FOR ANDCO "Eagle" LINEAR ACTUATOR ON A R&P SLIDE GATE

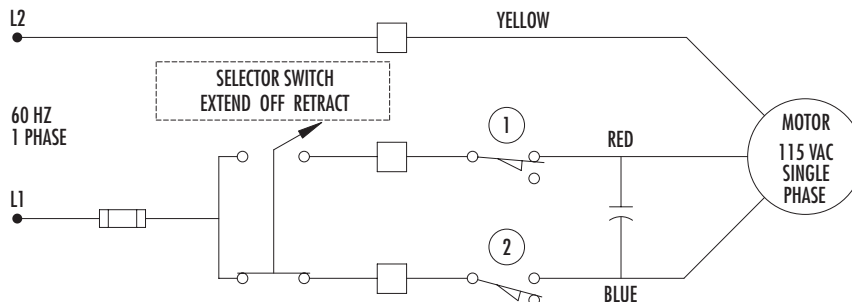

- ① INTERNAL EXTEND POSITION LIMIT SWITCH
 - ② INTERNAL RETRACT POSITION LIMIT SWITCH
 - CUSTOMER CONNECTION IN ACTUATOR
- NOTE:** ACTUATOR SHOWN IN FULL RETRACT POSITION.

LIMIT SWITCHES ARE THE ONLY DEVICES PROVIDED. ANY STARTER, PUSH BUTTON CONTROL OR INDICATOR LIGHTS ARE TO BE SUPPLIED BY CUSTOMER.